

PAD2-P-054-HR

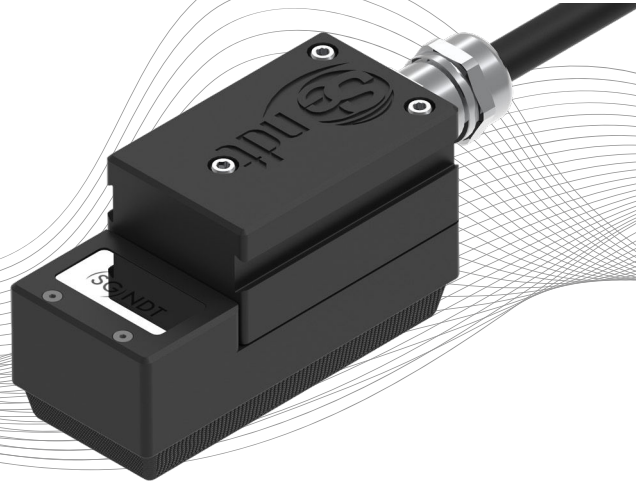

EKOSCAN PAD probes deliver the ideal balance of operator comfort and technical performance. Purpose-built for weld and pipe inspection, with or without an encoder, they handle surfaces ranging from low-radius curves to flat geometries. Rugged, easy to handle and engineered around the inspector, they are built to perform shift after shift.

The new PAD2 series introduces a rugged connector and ultra-resistant cushion coating that were field-tested to withstand harsh environments and abrasive surfaces.

The PAD2-P-054-HR is a high-resolution probe whose cushioned backing absorbs surface irregularities for stable and repeatable readings.

SHAPE probes can be tailored to application specific requirements, making them the ultimate tool for surface Eddy Current Array inspection.

PAD2-P-054-HR

Technology	Printed Coils
Frequency Range	100kHz – 2MHz
Coil quantity	2 Rows of 32 Intertwined (total 64)
Coil OD	3.5mm
Topology	Short Single Driver
Channels	31 Axial, 31 Transverses (total 64)
Probe Coverage	54mm
Curve radius	>50mm
Resolution	0.5mm
Minimum sizeable indication	1.75mm Axial, 1.75mm Transverse
Maximum Lift-Off	1.25mm
Cable length	3m



PAD2-P-054-HR

Interchangeability

The cushioned array detaches from the cable and multiplexer (MUX) assembly with a single tool, allowing quick swaps to arrays offering different coverage, resolution or topology to suit the inspection at hand.

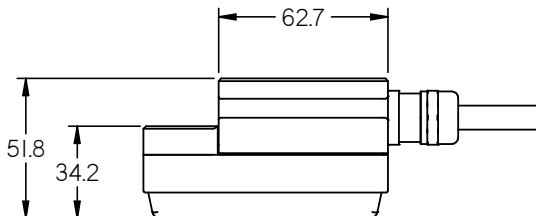
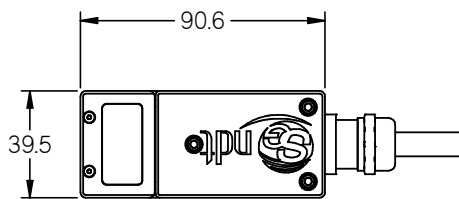
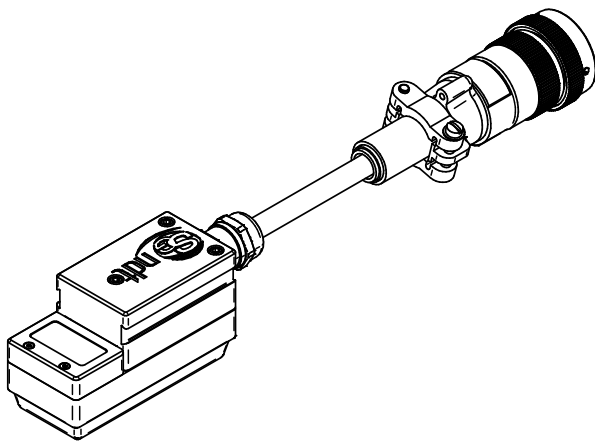
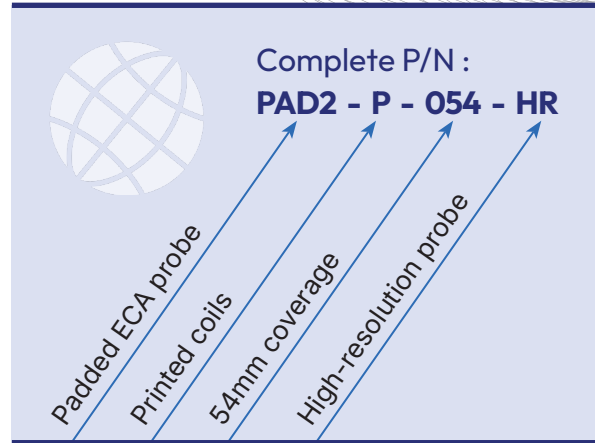

Cable P/N : CBL5-ECA2-03M

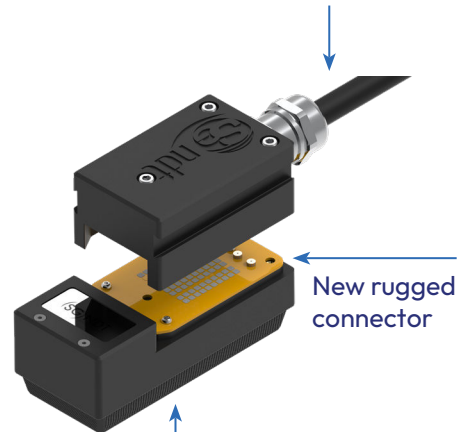

Array P/N : SPAD2-P-054-HR

Advancing diagnostic solutions
Powering industrial inspections

ekoscan-ndt.com

EKOSCAN

