



SHAPE2-P-053-MR



EKOSCAN SHAPE probes deliver the ideal balance of flexibility and technical performance on surfaces with varying curvatures and geometries. Handheld or mounted in a compact probe holder, they are the versatile tool of choice for initial trials and proof-of-concept work before transitioning to a fixed-geometry rigid probe.

The new SHAPE2 series introduces a rugged connector and cable, field-tested to withstand harsh environments and difficult-to-access inspections.

The SHAPE2-P-053-MR is a mid-resolution probe balancing sensitivity and coverage, with a rubber backing that combines durability with flexibility to follow complex geometries where access is a primary challenge.

SHAPE probes can be tailored to application specific requirements, making them the ultimate tool for surface Eddy Current Array inspection.

SHAPE2-P-053-MR

Technology	Printed Coils
Frequency Range	50kHz – 500kHz
Coil Quantity	2 Rows of 16 Intertwined (total 32)
Coil OD	3.5mm
Topology	Long Single Driver
Channels	31 Axial, 15 Transverses (total 46)
Probe Coverage	53mm
Curve Radius	>50mm
Resolution	2mm
Minimum Sizeable Indication	3.5mm Axial, 3.5mm Transverse
Maximum Lift-Off	2.75mm
Cable Length	3m



SHAPE2-P-053-MR

Interchangeability

The flexible array is easily detached from the cable and multiplexer (MUX) assembly and replaced using a single tool. This means that the array can be quickly and easily replaced by other similar arrays with a different coverage, resolution or topology.

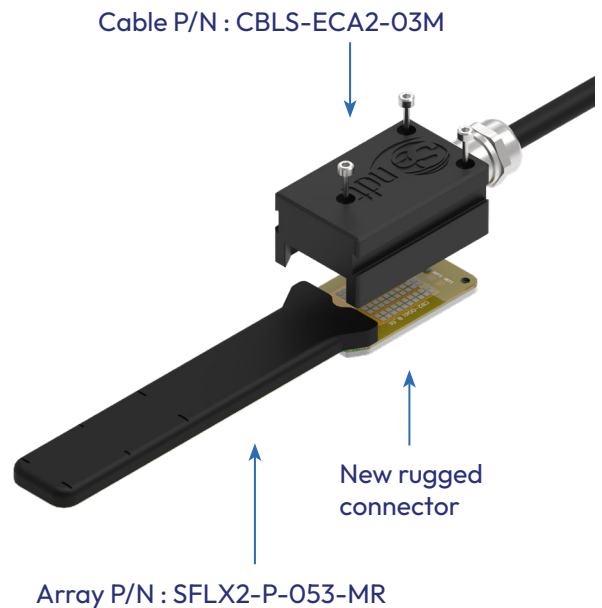
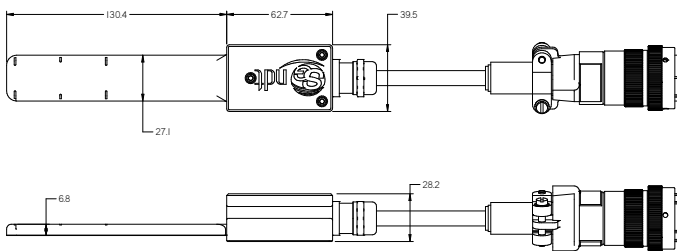
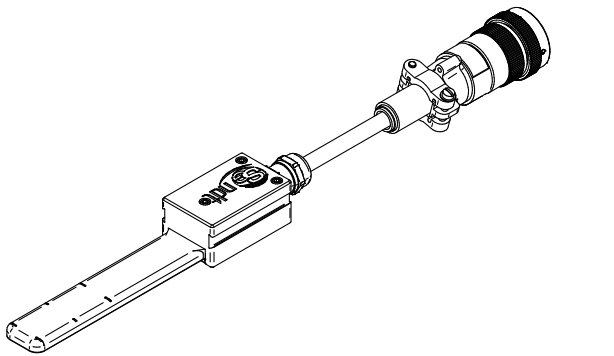
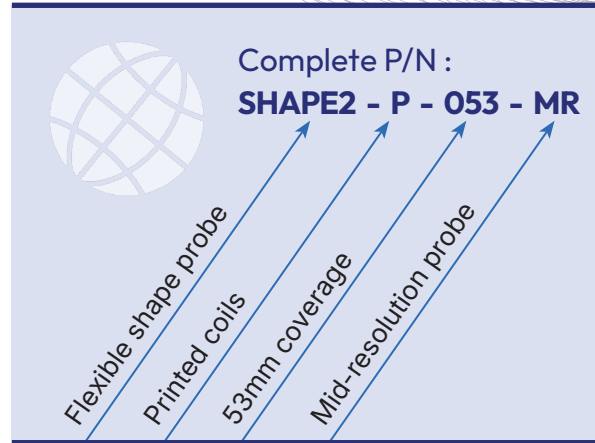

Advancing diagnostic solutions
Powering industrial inspections

ekoscan-ndt.com

EKOSCAN

