

# PAD-P-054-HR

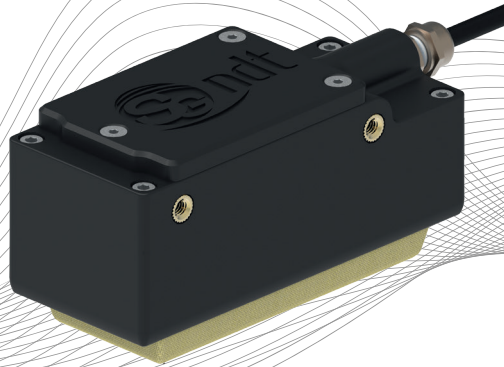
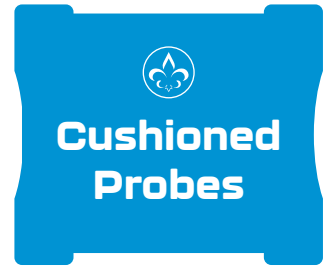

The SG NDT Cushion probes are an excellent choice for inspectors seeking both comfort and technical performance. They are specifically designed for inspecting smooth surfaces, clean welds, pipes, or semi-flat to flat structures with or without an encoder. These probes are ideal for inspecting surfaces with low-radius curves through to flat surfaces. They are durable, easy to manage, and have been designed with the inspector in mind.

The PAD-P-054-HR probe is a high-resolution inspection probe with a wear-resistant Kevlar cushioned face that can conform to gentle geometry changes. These probes have been field-proven as an excellent choice for a range of inspection requirements.

The cushioned probe can be customized to meet specific requirements upon request, making it the ultimate tool for surface Eddy Current Array examination.

## PAD-P-054-HR

Technology	PCB Coils
Frequency Range	100kHz – 800kHz
Coil OD	3.5mm
Coil Quantity	2 Rows of 32 Intertwined Coils (total 64)
Probe Coverage	54mm
Topology	Short Single Driver
Channels	31 Axial, 31 Transverses (total 62)
Resolution	1.75mm Axial, 1.75mm Transverse
Curve Radius	> 50mm
Typical Detectable Defect	> 0.5mm
Cable Length	3m Standard
Maximum Lift-Off	1.25mm

# PAD-P-054-HR

## Interchangeability

The cushioned array is easily detached from the cable and multiplexer (MUX) assembly and replaced using a single tool. This means that the array can be quickly and easily replaced by other similar arrays with a different coverage, resolution or topology.

Complete P/N :  
**PAD - P - 054 - HR**

Padded ECA probe  
Printed coils  
54 mm coverage  
High-resolution probe

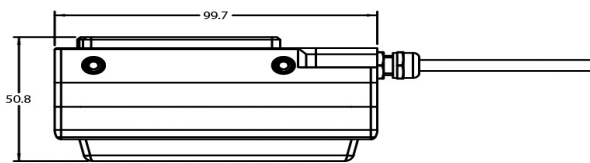
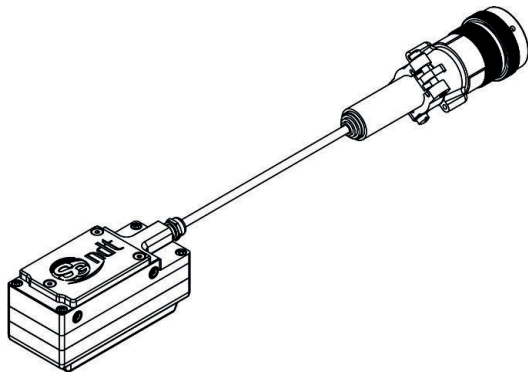

Cable P/N : **CBL5-ECA-03M**

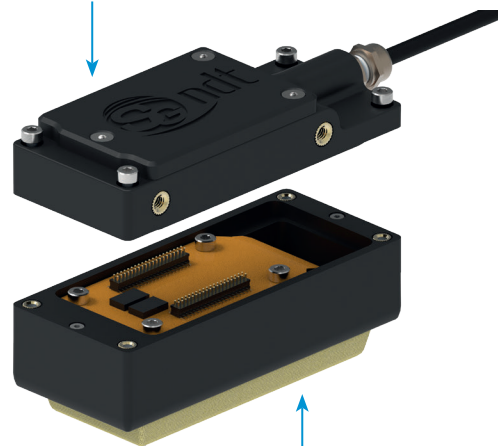

Array P/N : **SPAD-P-054-HR**

**Through innovation,**  
we surpass standard expectations

visit us online at: [sgndt.com](http://sgndt.com)