

SPEN-WELD-S-HT

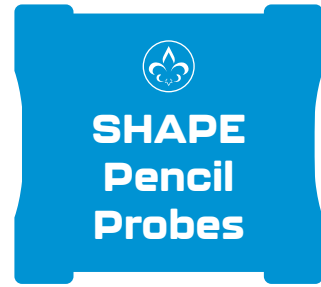

Pencil Probes

Pencil-style probes are designed for precise handheld inspections of carbon steel and stainless-steel welds, even on rough surfaces and painted finishes.

Featuring advanced dynamic lift-off technology, these probes enable efficient inspection of painted welds without requiring paint removal.

The SPEN-WELD-S-HT model is equipped with a durable, abrasion-resistant, straight ceramic tip, making it ideal for applications at elevated temperatures.

Each probe includes integrated memory to store calibration data and set-ups, ensuring reliable and accurate measurements.

Customizations are available upon request to meet specific inspection requirements.

SPEN-WELD-S-HT-03M

Cable Length	3m standard
Frequency Range	50kHz fixed
Probe Coverage	7mm
Topology Tangential	Eddy Current
Channels	1 Depth Channel 1 Length Channel
Resolution	3.75mm
Maximum Lift-Off	4mm
Typical Penetration	Depth Up to 5mm
Typical Detectable Defect	>3mm
Maximum Temperature	110°C
Standard Connector	41-pin Amphenol compatible with SG NDT electronics. Can be customized.



SPEN-WELD-S-HT

Dynamic Lift-Off Compensation

Dynamic lift-off compensation ensures that crack detection signals remain unaffected by variations in lift-off, such as differences in paint thickness. This feature eliminates the need for complex calibration processes and reduces the risk of operator errors during inspections.

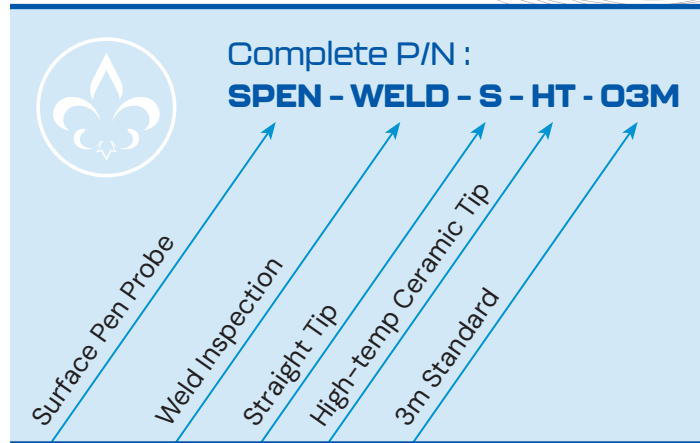

*Cable P/N : (03M) (05M) (10M)

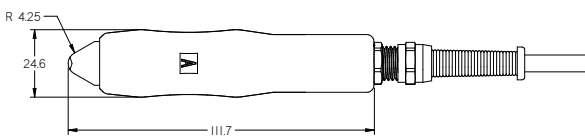
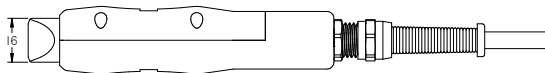
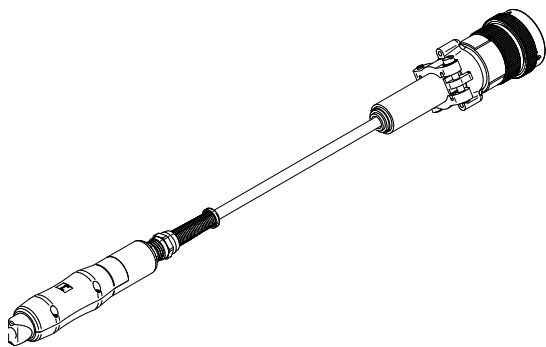

Through innovation,
we surpass standard expectations

visit us online at: sgndt.com

